



## Outback® Patio Heaters



A regulator of an approved type is required to operate this unit. A regulator of 28-30mbar must be used for butane and 37mbar for propane. For more details on compatible regulators for your patio heater, please contact your local gas supplier.



0359

Photographs are not to scale.  
Specifications subject to change  
without prior notice.



### WARNING

- **For outdoor use only.**
- **Read instructions before using the appliance. Failure to follow instructions could result in death, serious bodily injury, and/or property loss.**
- **Warning: accessible parts may be very hot. Keep young children away.**
- **Do not move the appliance during use.**
- **Turn off the gas supply at the gas bottle after use.**
- **Any modification of the appliance, misuse, or failure to follow the instructions may be dangerous and will invalidate your warranty. This does not affect your statutory rights.**
- **Retain these instructions for future reference.**
- **Leak test annually. Check the hose connections are tight and leak test each time you reconnect the gas bottle.**

### FOR YOUR SAFETY

If you smell gas:

1. **Shut off gas to the appliance.**
2. **Extinguish any open flame.**
3. **If odour continues, discontinue use and contact your local dealer.**

### FOR YOUR SAFETY

1. **Do not store or use petrol or other flammable vapours or liquids in the vicinity of this or any other appliance.**
2. **A gas bottle not connected for use shall not be stored in the vicinity of this or any other appliance.**

## A. Parts List

Code	Part	Qty
Heater Components		
A1	Reflector	1
A2	Burner Assembly	1
A3	Knob*	1
A4	Control Panel*	1
A5	Ignition Pushbutton*	1
A6	Hose*	1
A7	Post	1
A8	Table Half	2
A9	Door	1
A10	Base Top	1
A11	Base Support	3
A12	Base Hull	1
A13	Base	1
A14	Wheel Locknut	2
A15	Wheel	2
A16	Wheel Axle Washer	2
A17	Wheel Axle Bracket	1
Hardware (For more details, see Hardware Reference diagram)		
B1	M6x20 Hex Bolt	8
B2	Large Plain Washer	9
B3	M6 Hex Locknut	8
B4	M4x15 Flat Screw	6
B5	Small Plain Washer	6
B6	M4 Hex Nut	6
B7	1/4UNCx12 Bolt	8
B8	Spacer	1
B9	Latch	1
B10	Table bracket	2
*Pre-Assembled Component		
Specifications subject to change without notice.		

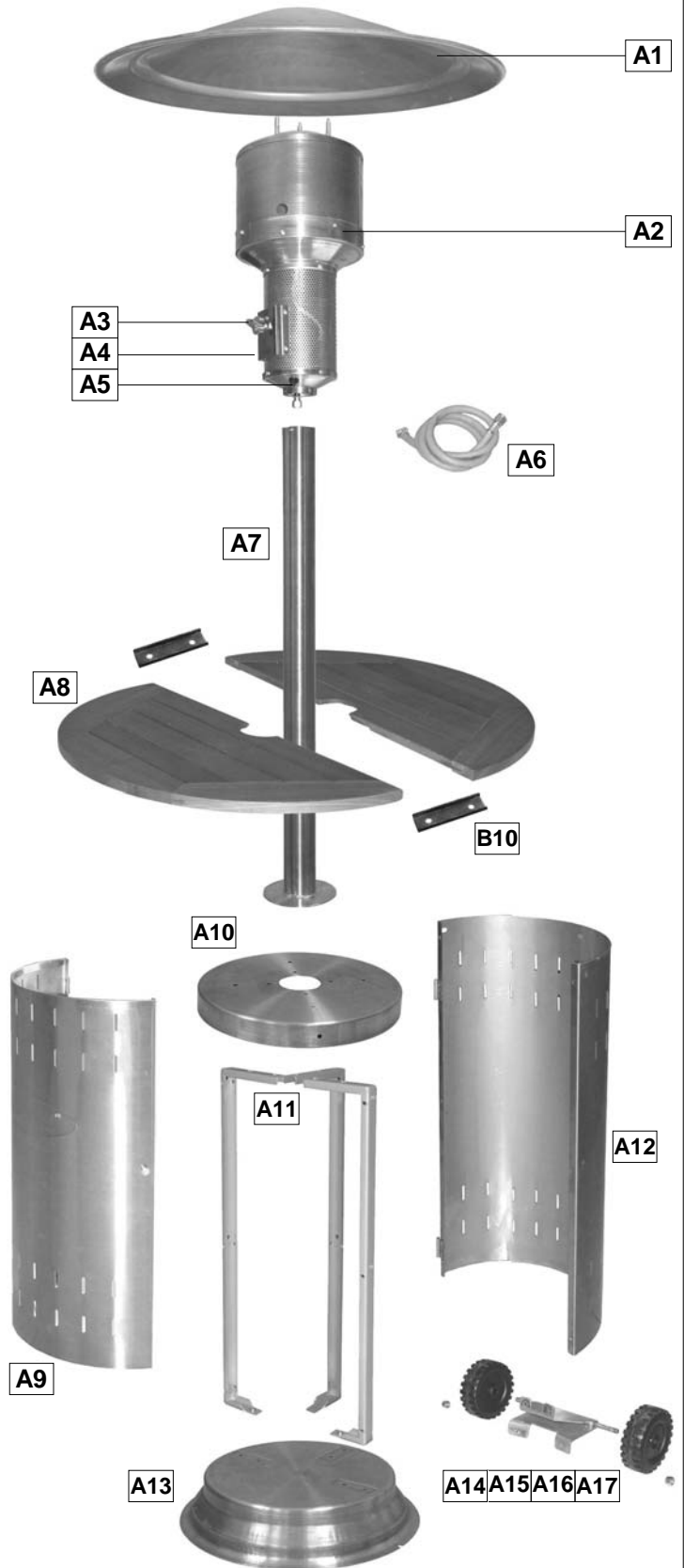

## **B. Hardware Reference Diagram**

Specifications subject to change without prior notice.

Part B1 (7pcs), Part B2 (7pcs), Part B3 (7pcs)

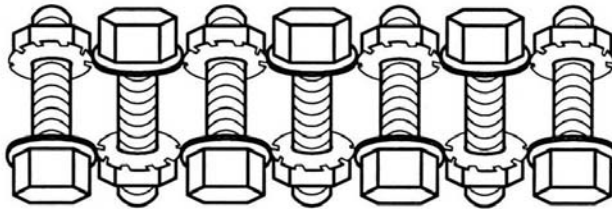

Part B7 (8pcs)

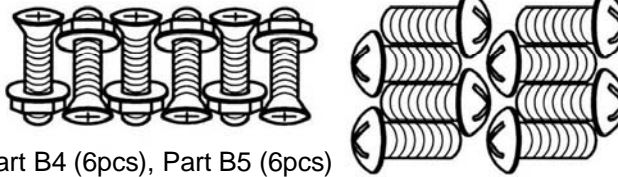

Part B4 (6pcs), Part B5 (6pcs)  
Part B6 (6pcs)

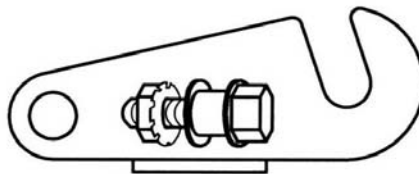

Part B1 (1pc)  
Part B2 (2pcs)  
Part B3 (1pc)  
Part B8 (1pc)  
Part B9 (1pc)

## C. Assembly

### ▲ TOOLS NEEDED FOR ASSEMBLY:

Medium size flat blade or Phillips/crosspoint screwdriver, adjustable spanner or metric spanner set.

▲ Remove all packing materials from the components before assembly. Two people are required to perform assembly of the patio heater as it involves handling of large, heavy parts which may be difficult for one person to handle. Please read the instructions thoroughly and carefully before assembly and use.

1

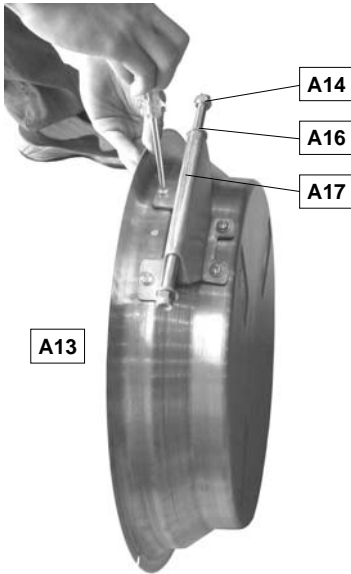

Remove the four base screws from the base (A13), align the holes of the wheel bracket (A17) with the holes in the base, fix with the four base screws and slide the wheel axle washers (A16) and wheels (A15) onto the axle and secure with locknuts (A14).

2

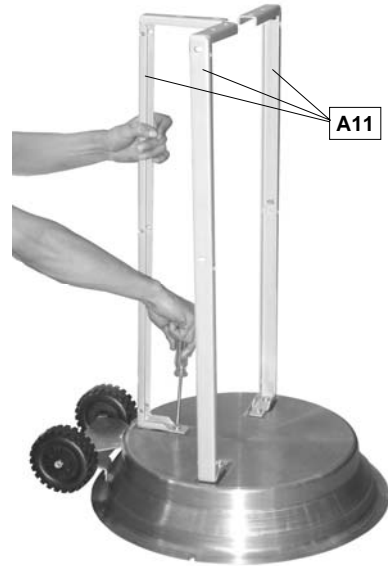

Remove the six base support screws from the base and assemble the base supports (A11). The additional 3 slots in the base hull must be positioned at the top. **WARNING:** Do not tighten the screws fully until step 3 is completed.

3

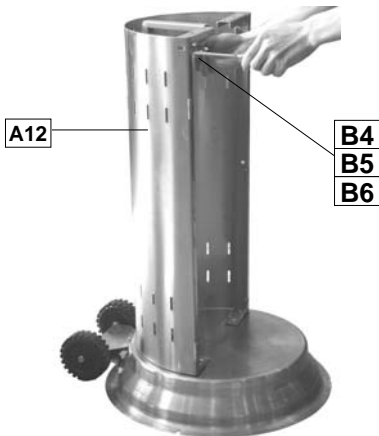

Assemble the base hull (A12) using the flat screws (B4), small plain washers (B5) and M4 hex nuts (B6). The hull is secured using only the two side base supports. The additional 3 slots in the base hull must be positioned at the top. Now fully tighten the base support screws shown in step 2.

4



Align the three holes of the base top (A10) with the holes in the base supports, and secure the cover by threading large plain washers (B2) onto each bolt (B1), insert the bolts through the aligned holes, and secure with locknuts (B3).

Align the four holes of the post (A7) with the holes in the base top (A10). Thread large plain washers (B2) onto each bolt (B1), insert the bolts through the aligned holes, and secure with locknuts (B3).

5



Fit the door latch (B9) by inserting an M6x20 bolt (B1) through a large plain washer (B2) and spacer (B8). Place the door latch over the spacer, insert the bolt through another plain washer (B2), base hull and secure with an M6 locknut (B3).

6



Remove the 4 screws and washers from the lower flange of the burner head. NB - Hose joints should be leak tested during assembly as detailed on P. 8. Feed the gas hose down through the post (A7) into the base assembly. Secure the burner head to the post using the 4 screws and washers.

7

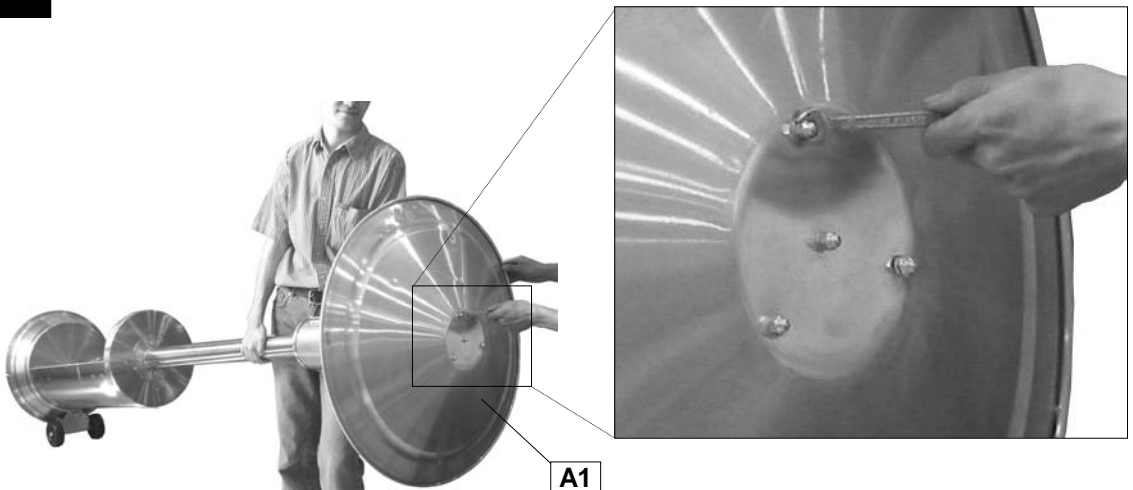

Remove all washers and acorn nuts from the studs on top of the burner head (A2). Place a washer on each stud and slot the reflector (A1) onto the burner head studs. Secure with the remaining 4 washers and acorn nuts.

8

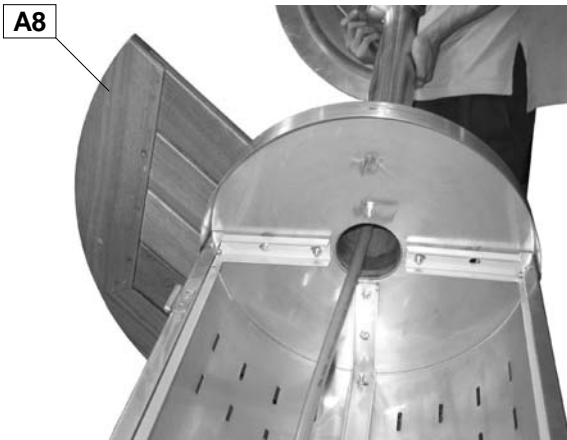

**Note:** please go to step 11 if the table is not included for the model you purchased.

Position one table half (A8) onto the base top. Ensure the notches in the underside of the table correspond with the bolt heads of the base top.

9

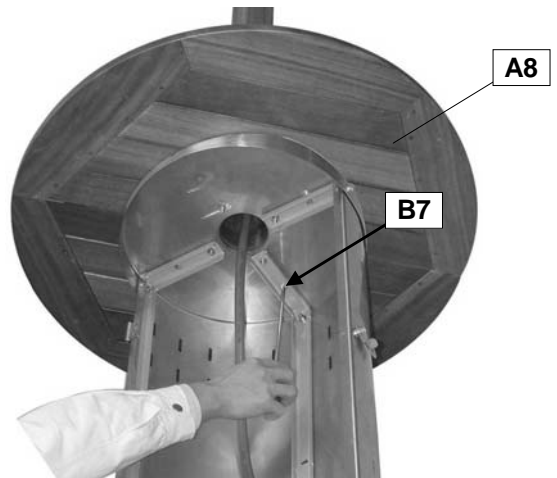

From inside the hull, secure the table half (A8) to the base top using the round head bolts (B7).

Repeat steps 8 and 9 for remaining half of table.

10

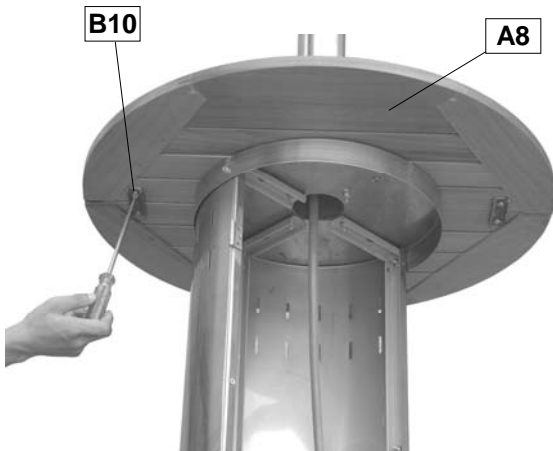

From inside of the tables, secure the table bracket (B10) to the two table half together using the table bracket bolts (B7).

11



Attach the door (A9).

Confirm the heater control knob is turned to the PILOT position and connect the gas hose to your regulator and the regulator to your gas bottle following your regulator supplier instructions.

**ASSEMBLY IS NOW COMPLETE.**

**PROCEED TO THE NEXT PAGE FOR INSTRUCTIONS ON OPERATION AND MAINTENANCE.**

## **D. For Your Safety**

If you smell gas:

- Turn off gas supply at bottle.
- Extinguish all naked flames; do not operate any electrical appliances.
- Ventilate the area.
- Check for leaks as detailed in this manual.
- If odour persists, contact your dealer or gas supplier immediately.

## **E. Important Information**

Please read these instructions carefully before assembly and use.

- Retain these instructions for future reference.
- **For outdoor use only – do not use indoors. This appliance should never be used in basements or below ground level.**
- Ensure the heater stands on a firm level surface.
- **Always turn off the gas at the cylinder whenever the heater is not alight! Turning the patio heater control knob fully clockwise does not close off the gas supply!**
- For use with LPG bottled gas only. A fixed pressure regulator of 28-30mbar must be used for butane or 37mbar for propane. The use of an adjustable regulator is dangerous and must never be used with this heater.
- LP gas cylinders must not be stored or used in the horizontal position. A leak would be very serious and liquid could enter the gas line.
- These instructions are only valid if your country is one of the following listed country codes on the appliance. If this code is not present on the appliance, it is necessary to refer to the technical instructions, which will provide the necessary information concerning the modification of the appliance to the conditions of use for the country.  
**(Country Codes: DK, FI, NL, NO, SE, BE, ES, FR, GB, IE, IT, LU, PT, IN, IL, IS, JO, KW, LB, MY, MX, SA, CZ, CY, EE, GR, HU, LV, LT, MT, PL, SI)**
- Before installation, check that the local distribution conditions, nature of gas, and pressure, and adjustment of the appliance are compatible.
- Do not use heater where the reflector is within 1.5m of any flammable structure or surface or any other surface that may be affected by heat, such as glass or plastic.
- Do not move the heater while alight.
- This appliance must not be left unattended when lit.

- Never operate the heater with the top half covered (burner head, reflector, etc.)
- Parts of this heater can become very hot – care must be taken when children, elderly people, and animals are present.
- When the heater is not alight, always turn off gas at the bottle or cylinder valve.
- Do not store flammable materials near this heater.
- Do not use aerosols near this heater.
- Failure to follow the manual's instructions could result in serious injury or damage.
- If you have any queries regarding these instructions, contact your local dealer.
- If the appliance is not alight because the pilot has become extinguished, the hose will still be full of gas which may liquefy in cold weather or leak out if the system is not sound. **IT IS ESSENTIAL THAT THE CYLINDER IS TURNED OFF AT ALL TIMES WHEN THE HEATER IS NOT ALIGHT.**
- As with other free standing garden equipment, the patio heater may become unstable during strong winds. For this reason, we do not recommend outdoor storage or use during strong winds. For added safety, the heater can be secured to the ground using the holes provided in the base.
- Remove the gas bottle before moving the patio heater.

## **F. Gas and Regulator Information**

This heater, hose, (and regulator, if included), are approved for use in the UK. The heater is also approved for use in other countries as listed in the Technical Specifications included in the heater manual. If the heater is intended to be used outside of the UK, the consumer MUST seek advice from the local qualified gas supplier as to the suitability of the heater and with regards to the correct hose and regulator that they should be using.

This appliance can use either propane or butane LPG bottled gas. For optimal performance we recommend that only propane gas is used. Propane gas is supplied under a number of different names and bottle colours. Never store the gas bottles inside a building. If in doubt, please consult your gas dealer/distributor.

For optimal performance, we suggest the following:

<b>Model</b>	<b>Gas</b>	<b>Bottle Size</b>
Outback® Patio Heater	Propane	10kg

Suitable regulators for butane must have an outlet pressure of 28-30mbar. For propane, the regulator should have an outlet pressure of 37mbar. **YOU MUST HAVE THE PROPER REGULATOR AND BOTTLE IN ORDER FOR THE HEATER TO OPERATE SAFELY AND EFFICIENTLY. USE OF AN INCORRECT OR FAULTY REGULATOR IS DANGEROUS AND WILL INVALIDATE ANY WARRANTY.** Please consult your local gas dealer for the most suitable gas bottles and regulators.

## **G. Installation**

### **G1. Selecting a Location**

This heater is for outdoor use only and should be placed in a well-ventilated area. Ensure that it is not placed UNDER any combustible surface. Do not use heater where the reflector is within 1.5m of any flammable structure or surface that may be affected by heat, such as glass or plastic. Ensure the heater stands on a firm, level surface. Keep this heater away from any flammable materials!

### **G2. Precautions**

Make sure the gas supply bottle is placed level within the base. Should you need to change the gas bottle, confirm the gas is turned off at the cylinder or regulator, and there are no sources of ignition (cigarettes, open flame, sparks, etc.) near before proceeding. Hose which can be used with this heater must conform with BS 3212 Type 2. Length of hose for use with this heater is 1.40m. If hose is not supplied with your heater, please contact an authorised gas supplier or distribution agent. Ensure that the hose bore and regulator nozzle are compatible. The hose should be secured to the regulator nozzle using a Jubilee clip or similar. Inspect the gas hose to ensure it is free of any twisting or tension. The hose should hang freely with no bends, folds, or kinks that could obstruct free flow of gas. Always inspect the hose for cuts, cracks, or excessive wear before use. If the hose is damaged, it must be replaced with hose suitable for use with LPG and meet the national standards for the country of use. *N.B.-The date on U.K. orange hose is the date of manufacture, not the expiry date.*

### **G3. Fixing the Regulator to the Gas Bottle**

Confirm the heater control knob is turned fully clockwise to the "PILOT" position. Connect the regulator to the gas bottle according to your regulator and bottle dealer's instructions.

### **G4. Leak Testing (To be performed in a well-ventilated area.)**

Confirm the control knob is turned fully clockwise to the "PILOT" position. Open the gas control at the cylinder. Check for leaks by brushing a

solution of ½ water and ½ soap over all gas system joints, including all valve connections, hose connections and regulator connections. It may be necessary to disassemble some of the parts in order to leak test the unit. NEVER USE AN OPEN FLAME to test for leaks at anytime. If bubbles form over any of the joints, there is a leak. Turn off the gas supply and retighten all fittings. Repeat test. If bubbles form again, do not use the heater. Please contact your local dealer for assistance. Leak test upon first receipt, and annually thereafter. Be sure to reassemble the unit properly before use.

## **H. Operation**

### **H1. Warning**

- Before proceeding, make certain that you understand the IMPORTANT INFORMATION section of this manual.

### **H2. Lighting the Heater (See Diagram 1)**

- Open the gas control valve on the gas bottle or regulator.
- Push in the knob at the "PILOT" position.
- While pressing down the knob at the "PILOT" position, repeatedly press "SPARK" button to ignite the pilot.
- Push knob in for a minimum of 10 seconds, and visually confirm proper lighting of the pilot. If the pilot fails to light, repeat lighting sequence and hold knob in for 20 seconds. (When using with a new cylinder or after changing a cylinder, you may need to hold the knob in for as much as one minute in order to purge all air from the gas train.)

Diagram 1

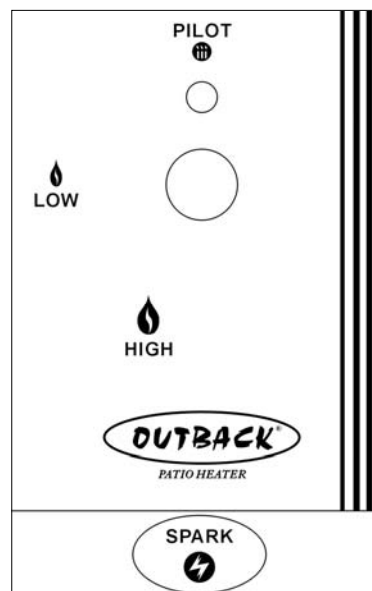

- The control can then be turned in an anti-clockwise direction to the “LOW” or “HIGH” position. DO NOT ATTEMPT TO TURN THE CONTROL KNOB WITHOUT RELEASING FROM ITS PUSHED-IN POSITION. FAILURE TO CARRY OUT THIS INSTRUCTION COULD RESULT IN DAMAGE TO THE VALVE ASSEMBLY.
- In windy weather, light and operate the heater in an area protected from the wind. Do not move the heater while it is alight.
- On the main burner, the flames should ignite in a circular fashion around the edges of the burner. Ensure the flames are burning evenly around the burner.
- The optimal colour of a properly burning flame is blue with yellow tips.
- If the pilot or main burner fail to light, turn control knob fully clockwise to the “PILOT” position, turn gas off at the cylinder and wait 5 minutes before repeating lighting procedure.
- If pilot or main burner STILL fails to ignite, turn control knob fully clockwise to the “PILOT” position, turn gas off at the cylinder and wait 5 minutes, then follow the steps in the section titled ‘Manual Lighting Procedure’.

### **H3. Manual Lighting Procedure**

- Open the gas control valve on the gas bottle or regulator.
- Insert a lit match through the match-lighting hole in the mesh of the burner assembly. Position the match near the pilot.
- Push in the knob at the “PILOT” position.
- Push knob in for a minimum of 10 seconds, and visually confirm proper lighting of the pilot. If the pilot fails to light, repeat lighting sequence and hold knob in for 20 seconds. (When using with a new cylinder or after changing a cylinder, you may need to hold the knob in for as much as one minute in order to purge all air from the gas train.)
- The control can then be turned in an anti-clockwise direction to the “LOW” or “HIGH” position. DO NOT ATTEMPT TO TURN THE CONTROL KNOB WITHOUT RELEASING FROM ITS PUSHED-IN POSITION. FAILURE TO CARRY OUT THIS INSTRUCTION COULD RESULT IN DAMAGE TO THE VALVE ASSEMBLY.
- In windy weather, light and operate the heater in an area protected from the wind. Do not move the heater while it is alight.
- On the main burner, the flames should ignite in a circular fashion around the edges of the burner. Ensure the flames are burning evenly around the burner.
- The optimal colour of a properly burning flame is blue with yellow tips.
- If the pilot or main burner fail to light, turn

control knob fully clockwise to the “PILOT” position, turn gas off at the cylinder and wait 5 minutes before repeating manual lighting procedure.

- If pilot or main burner STILL fails to ignite, turn control knob fully clockwise to the “PILOT” position, turn gas off at the cylinder, and contact your local authorised gas dealer.

### **H4. Shut down procedure**

- Turn knob fully clockwise to the “PILOT” position.
- Turn gas off at the cylinder or regulator.
- Let the heater cool down sufficiently before handling and/or moving.

## **I. Care and Maintenance**

Regularly clean your patio heater between uses and especially after extended periods of storage. Ensure the heater control is turned fully clockwise to the “PILOT” position, the gas is shut off at the cylinder, and the heater and its components are sufficiently cool before cleaning. Never douse the heater with water when its surfaces are hot.

### **I1. Heater Base and Post**

Use a damp cloth or sponge to wipe dirt and grime away. Do not use any abrasives or solvents, which can damage the surface paint.

### **I2. Fixings**

All screws and bolts, etc. should be checked and tightened on a regular basis.

### **I3. Table**

Your patio heater table is manufactured using a hardwood ideally suited to outdoor use. Its condition and appearance can be maintained by applying Teak oil or similar, as required. Hardwood will naturally weather and change its appearance. It is quite natural for small cracks to appear on the surface of the wood.

### **I4. Storage**

Do not leave the patio heater exposed to outside weather conditions or stored in damp, moist areas. To save space during long-term storage, the reflector can be removed by removing the acorn nuts that hold it in place. Take care to ensure the shape of the reflector is not damaged or deformed, as this will affect performance. When using the heater after extended periods of storage, re-attach the reflector by fastening it onto the burner head. The heater should never be operated without the reflector in place. If the heater is to be stored indoors, the gas bottle must be disconnected and left outside. The gas bottle should always be stored outside, in a dry, well-ventilated area, away

from any sources of heat or ignition. Do not let children tamper with the bottle. Heavy duty Outback® patio heater covers are available from your local Outback® stockist.

### 15. Service

We recommend your heater is serviced on an annual basis. Servicing should be carried out by a qualified Corgi gas technician. During storage in particular it is possible for insects or foreign material to get into the burner assembly, main jet or pilot light assembly and interfere with the correct operation of the heater. The jet on the pilot light is also very small and it is the main cause of the pilot not lighting if it becomes blocked. In addition, the burner mesh should be brushed to keep it clear of any deposits.

### J. Technical Specifications

<b>Model Name</b>	<b>PH04</b>
<b>CE Approval</b>	<b>0359 359BR216</b>
<b>Heat Input</b>	13.5kW
<b>Gas Consumption</b>	980g/hr
<b>Burners</b>	1
<b>Injector Size</b>	1.93
<b>Gas Types:</b> Butane or Propane	<b>Operating Pressure:</b> Butane - 28-30mbar Propane - 37mbar
<b>Countries of Use</b>	I <sub>3+(28-30/37)</sub> BE, CY, CZ, EE, FR, GR, IE, IS, IT, LV, LT, LU, PT, SK, ES, CH, GB I <sub>3B/P(30)</sub> CY, CZ, DK, EE, FI, GR, LV, LT, LU, MT, NL, NO, SK, SI, SE, TR I <sub>3B/P(50)</sub> AT, DE, HU, SK, CH I <sub>3B/P(36)</sub> PL
<b>Dimensions</b>	<b>750mm x 750mm x 2320mm</b>
<b>Net Weight</b>	<b>33.5kg</b>

For reference and correspondence, record your serial number here. (See sticker on side of patio heater.)

### Serial No. \_\_\_\_\_

This number may be required when ordering spare parts or accessories. A part reference number may also be required where applicable.

In the unlikely event that you experience problems with this heater, please contact:

Customer Service  
Outback UK  
Unit 2 Farleigh Hill  
Tovil  
Maidstone  
Kent  
ME15 6RG  
Tel: 01622 671771  
Fax: 01622 673101

e-mail: [customerservice@outbackuk.com](mailto:customerservice@outbackuk.com)